

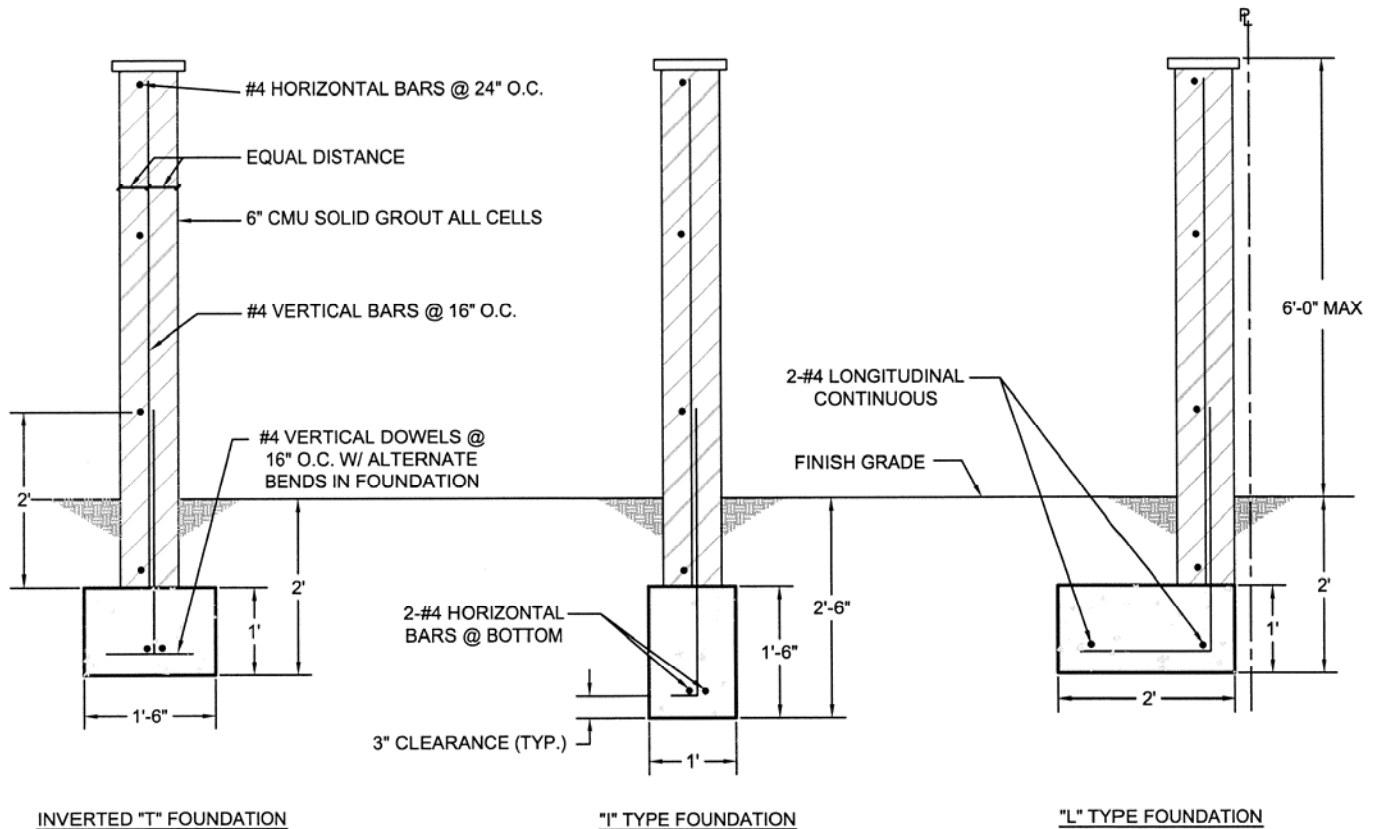

6" CONCRETE MASONRY BLOCK FENCE WALL DETAIL

6'-0" IN HEIGHT MAXIMUM



GENERAL SPECIFICATIONS & NOTES

1. Concrete mix for footing to be 1 part cement to 2-1/2 parts sand to 3-1/2 parts gravel with a maximum of 7-1/2 gallons of water per sack of cement. $f'c = 2500$ psi. Cement shall conform to ASTM C-150.
2. Concrete block units shall conform to ASTM C90, Grade N.
3. Reinforcing steel to be deformed and conform to A.S.T.M. specs. A 615 Grade 40 or Grade 60.
4. Rebar shall be centered in the concrete block.
5. Concrete block units are to be staggered and have vertical continuity of cells unobstructed.
6. Mortar mix for concrete to be 1 part cement to 1/4 part lime to 3 parts damp loose sand.
7. Grout mix for concrete block wall to be 1 part cement to 3 parts sand to which may be added not more than 1/10 part lime. Sufficient water is to be added to produce consistency for pouring without segregation of the constituents. The grout may contain 2 parts pea gravel, maximum size of 3/8".
8. First inspection to be after trenches are ready for concrete and all required steel is tied in place but before foundation concrete is poured. Second inspection to be, when first horizontal bar is in place with vertical and horizontal steel but not grouted.
9. Foundation must be poured against undisturbed soil with level ground on both sides of wall on all types of foundations (not retaining earth).
10. Masonry or concrete fences over 3'-6" in height shall require building permit (ORD #169.344).
11. Height of fence shall comply with all provisions of the zoning code.
12. Single Family Residential properties with walls built on property line must use "L" Type Foundation. Any Alley repair patch must comply with City of Beverly Hills Department of Public Works & Transportation, Civil Engineering Division Standard Drawing BH 114.

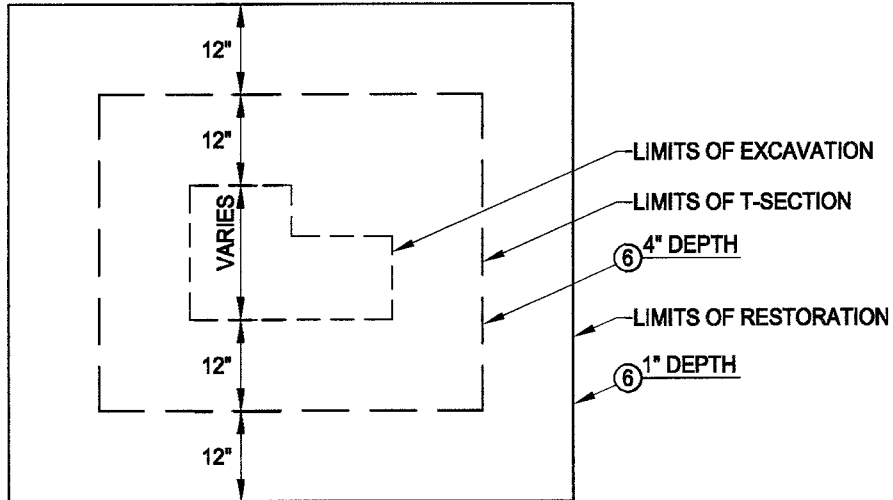

CASE I - PLAN

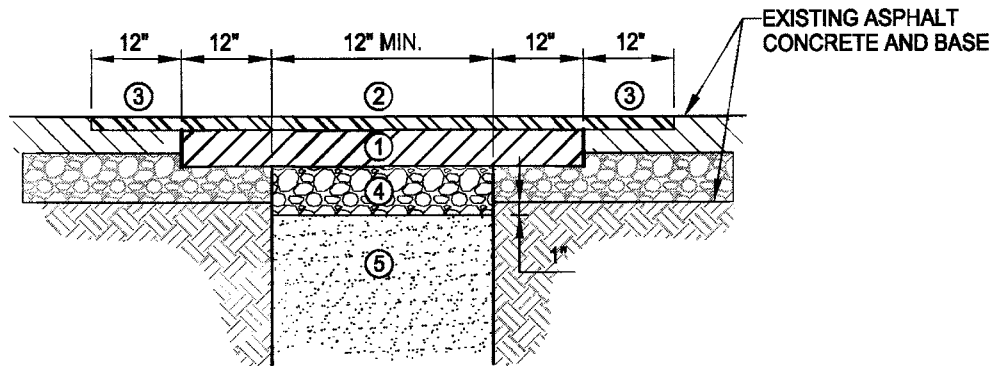

CASE I - EXISTING SECTION: ASPHALT CONCRETE

- ① CONSTRUCT NEW ASPHALT CONCRETE BASE COURSE, TYPE B, PG 64-10, 1" THICKER THAN THE EXISTING SECTION.
- ② CONSTRUCT NEW ASPHALT CONCRETE WEARING COURSE:

TYPES OF STREETS	DEPTH	ASPHALT CONCRETE
LOCAL RESIDENTIAL STREETS	1"	TYPE D2, PG-64-10
STREET WITH ASPHALT RUBBER AGGREGATE MEMBRANE (A.R.A.M.)	1"	TYPE D2, PG-64-10
COLLECTOR/MAJOR STREETS	1-1/2"	TYPE C2, PG-64-10

① AND ②: THE TOTAL THICKNESS OF ① + ② SHALL BE 4" MINIMUM FOR LOCAL OR COLLECTOR STREETS AND 6" MINIMUM FOR MAJOR STREETS.



PAVEMENT REPLACEMENT SECTION - CASE I

REVISIONS				CITY OF BEVERLY HILLS, CALIFORNIA		STANDARD DRAWING
MARK	DATE	DESCRIPTION		DEPARTMENT OF PUBLIC WORKS & TRANSPORTATION CIVIL ENGINEERING DIVISION		
						BH 114 SHEET 1 OF 4
			RECOMMENDED <i>[Signature]</i> CITY ENGINEER	DATE 7-30-09		
			APPROVED <i>[Signature]</i> PUBLIC WORKS DIRECTOR	DATE 7-31-09		

- ③ A. THE LIMITS OF THE RESTORATION SHALL BE A RECTANGULAR AREA EXTENDING A MINIMUM OF 12" BEYOND THE OUTER EDGE OF THE WIDEST PORTION OF THE T-SECTION. THE LIMITS SHALL BE SAWCUT AFTER BACKFILL OF TRENCH IS COMPLETED. THE EXISTING A.C. SHALL BE REMOVED TO A DEPTH EQUAL TO THE THICKNESS OF THE WEARING COURSE. REMOVAL BY COLD MILLING OR PNEUMATIC HAMMER IS ACCEPTABLE. IF THE REMOVALS ARE LESS THAN 5' APART OR LESS THAN 2' FROM A CONCRETE CURB, GUTTER OR CROSS GUTTER, THE RESTORATION SHALL BE CONTINUOUS BETWEEN EXCAVATIONS AND/OR THE EDGE OF THE CONCRETE.
- ④ CONSTRUCT NEW CRUSHED AGGREGATE BASE TO MATCH EXISTING THICKNESS OR 4" THICKNESS, WHICHEVER IS GREATER. COMPACT TO 95% OR RELATIVE DENSITY.
- ⑤ TRENCH BACKFILL SHALL BE EITHER:
 - A. NATIVE MATERIAL OR IMPORTED SOIL (IF NATIVE IS UNSUITABLE)
 - B. CRUSHED AGGREGATE BASE
 - C. TWO SACK CEMENT SAND SLURRY

COMPACTION TEST (USING CITY APPROVED METHOD) ARE REQUIRED UNLESS SLURRY OR CRUSHED AGGREGATE BASE IS USED.
- ⑥ SAWCUTTING WILL BE REQUIRED AROUND THE PERIMETER OF THE FINAL EDGE OF ALL EXCAVATIONS TO PROVIDE CLEAN, STRAIGHT, VERTICAL SIDES.
- 7. T-SECTIONS ARE 12" WIDE AS MEASURED FROM THE FINAL EDGE OF TRENCH (AFTER SLUFFING).
- 8. ALL TRAFFIC STRIPING AND/OR MARKINGS REMOVED BY RESTORATION WORK SHALL BE REPLACED.
- 9. ALL WORK SHALL BE CONSTRUCTED IN ACCORDANCE WITH THE CURRENT EDITION OF STANDARD SPECIFICATIONS FOR PUBLIC WORKS CONSTRUCTION ("GREENBOOK").
- 10. CONTRACTOR SHALL HAVE A VALID CLASS "A" OR "C12" CALIFORNIA CONTRACTOR'S LICENSE.

PAVEMENT REPLACEMENT SECTION - CASE I

REVISIONS				CITY OF BEVERLY HILLS, CALIFORNIA	
MARK	DATE	DESCRIPTION		DEPARTMENT OF PUBLIC WORKS & TRANSPORTATION CIVIL ENGINEERING DIVISION	
				RECOMMENDED  DATE <u>7-30-09</u>	STANDARD DRAWING BH 114 SHEET 2 OF 4
				APPROVED  DATE <u>7-31-09</u>	

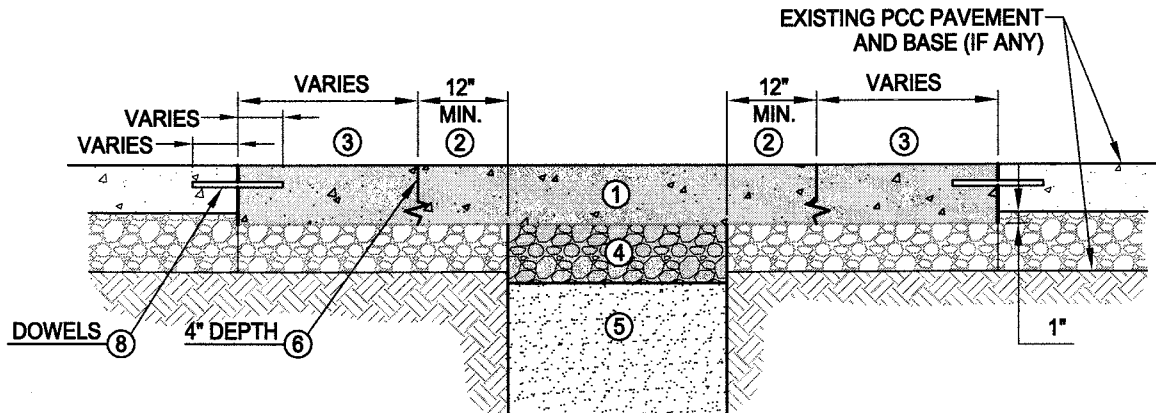

CASE II - EXISTING SECTION: PORTLAND CONCRETE CEMENT

- ① CONSTRUCT NEW PCC PAVEMENT 1" THICKER THAN THE EXISTING CONCRETE, 6" MINIMUM.
- ② THE EXACT LIMITS FOR REMOVAL SHALL BE DETERMINED BY THE CITY ENGINEER SUCH THAT JOIN LINES ARE NOT WITHIN 2'-6" OF EXISTING PAVEMENT JOINTS OR SIGNIFICANT CRACKS. IF THE EXCAVATIONS ARE LESS THAN 5' APART OR LESS THAN 2'-6" FROM A CONCRETE CURB, GUTTER OR EXPANSION JOINT, THE RESTORATION SHALL BE CONTINUOUS BETWEEN EXCAVATIONS AND/OR THE EDGE OF CONCRETE.
- ③ FOR PCC STREETS OR INTERSECTIONS THE LIMITS OF THE RESTORATION SHALL BE A RECTANGULAR AREA EXTENDING TO THE NEAREST CONSTRUCTION JOINT. THE STRUCTURAL SECTION OUTSIDE THE UTILITY TRENCH AREA SHALL BE EQUAL TO ① + ④.
- ④ CONSTRUCT NEW CRUSHED AGGREGATE BASE TO MATCH EXISTING THICKNESS OR 4" THICKNESS, WHICHEVER IS GREATER. COMPACT TO 95% OF RELATIVE DENSITY.
- ⑤ TRENCH BACKFILL SHALL BE EITHER:
 - A. NATIVE MATERIAL OR IMPORTED SOIL (IF NATIVE IS UNSUITABLE)
 - B. CRUSHED AGGREGATE BASE
 - C. TWO SACK CEMENT SAND SLURRY
 COMPACTION TEST (USING CITY APPROVED METHOD) ARE REQUIRED UNLESS SLURRY OR CRUSHED AGGREGATE BASE IS USED.
- ⑥ SAWCUTTING WILL BE REQUIRED AROUND THE PERIMETER OF THE FINAL EDGE OF ALL EXCAVATIONS TO PROVIDE CLEAN, STRAIGHT, VERTICAL SIDES.
- ⑦ DOWEL SIZE, SPACING, AND EMBEDMENT SHOULD BE AS FOLLOWS:

CONCRETE THICKNESS	SIZE AND SPACING	EMBEDMENT
6"	#4 @ 16" O.C.	4"
8"	#5 @ 16" O.C.	6"
10"	#6 @ 16" O.C.	8"

- 8. ALL TRAFFIC STRIPING AND/OR MARKINGS REMOVED BY RESTORATION WORK SHALL BE REPLACED.
- 9. ALL WORK SHALL BE CONSTRUCTED IN ACCORDANCE WITH THE CURRENT EDITION OF STANDARD SPECIFICATIONS FOR PUBLIC WORKS CONSTRUCTION ("GREENBOOK").
- 10. CONTRACTOR SHALL HAVE A VALID CLASS "A" OR "C8" OR "C12" CALIFORNIA CONTRACTOR'S LICENSE.

PAVEMENT REPLACEMENT SECTION - CASE II

REVISIONS		
MARK	DATE	DESCRIPTION



CITY OF BEVERLY HILLS, CALIFORNIA
 DEPARTMENT OF PUBLIC WORKS & TRANSPORTATION
 CIVIL ENGINEERING DIVISION

RECOMMENDED: *Chris T...* DATE 7-20-09
 CITY ENGINEER
 APPROVED: *[Signature]* DATE 7-31-09
 PUBLIC WORKS DIRECTOR

STANDARD DRAWING
BH 114
 SHEET 3 OF 4

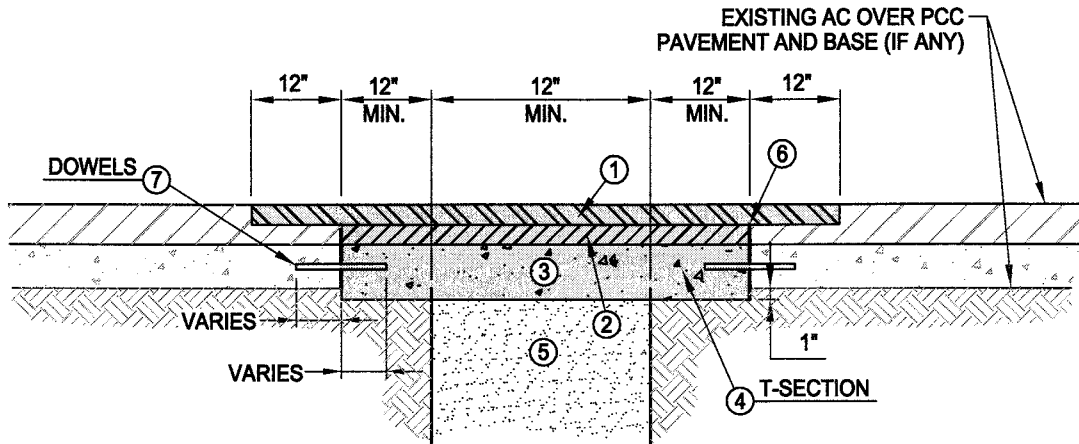

CASE III - EXISTING SECTION: ASPHALT OVER CONCRETE

- ① CONSTRUCT 1" NEW ASPHALT CONCRETE WEARING COURSE TYPE D2, PG 64-10.
- ② CONSTRUCT NEW ASPHALT CONCRETE BASE COURSE, TYPE B, PG 64-10.
- ③ CONSTRUCT NEW PCC PAVEMENT BASE 1" THICKER THAN THE EXISTING CONCRETE, 6" MINIMUM.
- ④ THE EXACT LIMITS FOR REMOVAL SHALL BE DETERMINED BY THE CITY ENGINEER SUCH THAT JOIN LINES ARE NOT WITHIN 2'-6" OF EXISTING PAVEMENT JOINTS OR SIGNIFICANT CRACKS. IF THE EXCAVATIONS ARE LESS THAN 5' APART OR LESS THAN 2'-6" FROM A CONCRETE CURB, GUTTER OR EXPANSION JOINT, THE RESTORATION SHALL BE CONTINUOUS BETWEEN EXCAVATIONS AND/OR THE EDGE OF CONCRETE.
- ⑤ TRENCH BACKFILL SHALL BE EITHER:
 - A. NATIVE MATERIAL OR IMPORTED SOIL (IF NATIVE IS UNSUITABLE)
 - B. CRUSHED AGGREGATE BASE
 - C. TWO SACK CEMENT SAND SLURRY
 COMPACTION TEST (USING CITY APPROVED METHOD) ARE REQUIRED UNLESS SLURRY OR CRUSHED AGGREGATE BASE IS USED.
- ⑥ SAWCUTTING WILL BE REQUIRED AROUND THE PERIMETER OF THE FINAL EDGE OF ALL EXCAVATIONS TO PROVIDE CLEAN, STRAIGHT, VERTICAL SIDES.
- ⑦ DOWEL SIZE, SPACING, AND EMBEDMENT SHOULD BE AS FOLLOWS:

CONCRETE THICKNESS	SIZE AND SPACING	EMBEDMENT
6"	#4 @ 16" O.C.	4"
8"	#5 @ 16" O.C.	6"
10"	#6 @ 16" O.C.	8"

- 8. ALL TRAFFIC STRIPING AND/OR MARKINGS REMOVED BY RESTORATION WORK SHALL BE REPLACED.
- 9. ALL WORK SHALL BE CONSTRUCTED IN ACCORDANCE WITH THE CURRENT EDITION OF STANDARD SPECIFICATIONS FOR PUBLIC WORKS CONSTRUCTION ("GREENBOOK").
- 10. CONTRACTOR SHALL HAVE A VALID CLASS "A" OR "C8" OR "C12" CALIFORNIA CONTRACTOR'S LICENSE.

PAVEMENT REPLACEMENT SECTION - CASE III

REVISIONS				CITY OF BEVERLY HILLS, CALIFORNIA	
MARK	DATE	DESCRIPTION		DEPARTMENT OF PUBLIC WORKS & TRANSPORTATION CIVIL ENGINEERING DIVISION	

RECOMMENDED	<i>[Signature]</i>	DATE	7-30-09
	CITY ENGINEER		
APPROVED	<i>[Signature]</i>	DATE	7-31-09
	PUBLIC WORKS DIRECTOR		

STANDARD DRAWING
BH 114
SHEET 4 OF 4